



LowTuS

ON-LINE LOW TURBIDITY
DIGITAL SENSOR FOR
DRINKING WATER APPLICATION
APPLICATIONS



APPLICATIONS

Raw water for drinking
water production
Drinking water
process control
Final Water
Monitoring
Filtered Water

ADVANTAGES

- 90-degree light-scattering Nephelometric method – ISO 7027.
- Ranges 0-10 NTU; 0-100 NTU
- Modbus RS-485 digital communication
- Self-cleaning of optical part
- Operation checking with Solid Tare

Major French actor specialized in the conception and manufacture of measuring sensors dedicated to water quality control for more than 70 years, the brand Ponsel of the company AQUALABO, offers its new Low Turbidity digital sensor for low-range turbidity measurements for drinking water production processes.

MEASUREMENT PRINCIPLE

The measurement principle is based on the measurement of Infra-Red light diffusion at 90° (ISO 7027) and allows continuous monitoring of the Turbidity measurement over low measurement ranges.

The new Low Turbidity sensor incorporates a new mechanical system for automatic cleaning of the measuring cell. This system prevents the build-up of contamination in the measuring field and on optical scattering and IR radiation cells.

An automatic de-bubbling system prevents bubbles from sticking to the optical windows so as not to introduce measurement errors.

Calibration can be performed using a turbidity standard (Formazine) and a quick functional check using the calibration reference cell (Solid Tare) supplied with each sensor (Premium version), making the calibration process easier and reproducible.

DIGITAL COMMUNICATION / BUILT-IN TRANSMITTER

The New Low Turbidity sensor connects to any type of recorder, transmitter, remote management system or PLC using a Modbus RS-485 input. As a result of sensor indexing, more than 200 sensors can be connected to a recorder.

Interference-proofing: pre-amplification built into the sensor and digital signal processing.

All calibration, history, user, and measurement data are processed directly in the New Low Turbidity Sensor and transmitted by a Modbus RS-485.

OPTIONS



*measurement
flow cell with
cleaning system*



Cleaning system

*Debubbling : rotating wiper to
push bubbles and deposits out
of the optical windows.*



Dry calibration tool

Manual use two positions for 2 steps :

- Dark level
- Low scattering level

DIMENSIONS

PREMIUM VERSION

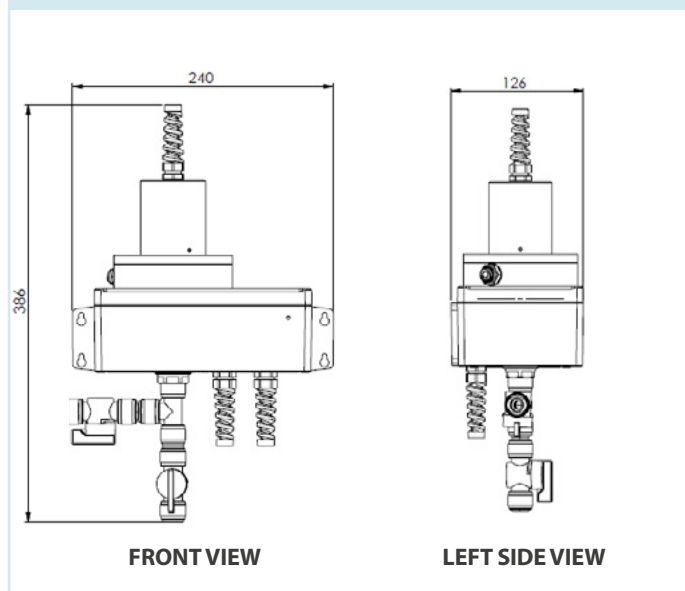

STANDARD VERSION

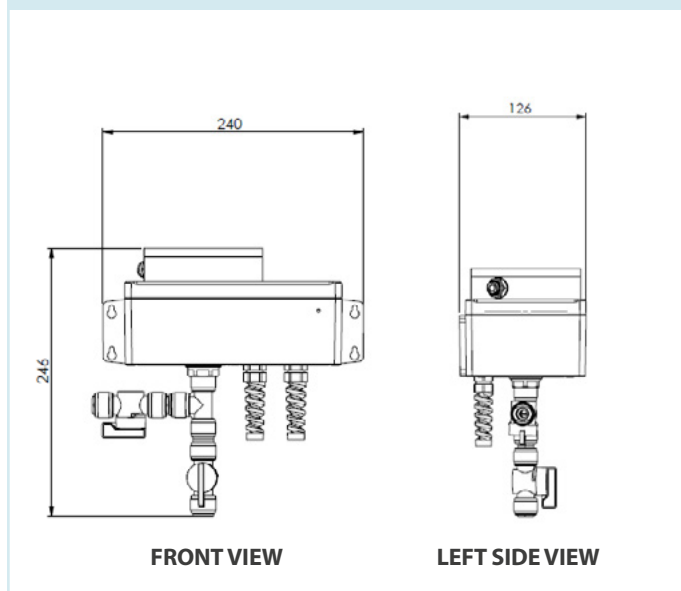

TECHNICAL CHARACTERISTICS

Measurements	
Measurement principle	Diffusion IR at 90° - ISO 7027
Measuring Range	0-10; 0-100 NTU & Automatic Range
Resolution	0,0001 NTU for [0,0002 to 9,9999 NTU] 0,001 NTU for [10,000 to 100,00 NTU]
Accuracy	Low range: +/-2% of reading or 0,1 NTU* High range: +/-5% or 0,3 NTU* *Highest value
Temperature	NTC
Temperature Accuracy	+/- 0.5°C
Type of detector	Si photodiode
Light sources	IR LED 850 nm
Measurement frequency min	0.75s (measure only), 6s (measure + cleaning)
Ingress Protection rating	IP65
Maximum pressure	3.5 bar
Débit eau Water Flow	100 ml/min to 1500 ml/min
Operating temperature	0-40°C
Storage temperature	0-50°C
Weight	1800 – 2000g depending on the version
Equipment	Body: Polycarbonate, POM-C, PE, polyamide Optical windows: Fused silica Cable: Bare wire with polyurethane sheath Seals: Nitrile Wiper unit: Silicon, Stainless steel
Wetted materials	Measurement cell: POM-C, Fused silica, Nitrile Wiper unit: Silicon, Stainless steel
Cable	9 shielded conductors in 3, 7 and 15m. Other lengths on request
Signal interface	Modbus ¹ RS-485 1. The sensor responds in Modbus including during Standby

	Measure only	Measure + Cleaning
Sensor Power Supply	5 ¹ - 26 ² VDC 1. Minimum voltage subject to cable length-related losses 2. 28.0V absolute maximum	6 ¹ - 26 ² VDC
Typical consumption at 5V / 6V	Automatic standby: less than 3.7 mA* (18.5 mW / 22.2 mW) Maximum peak current: 400 mA (10 ms)	
Maximum current during measurement	110 mA (550 mW)	300 mA (1800 mW)
Average current during measurement	25 mA (125 mW)	165 mA (990 mW)
Average current (1 measurement / 10s)*	10 mA (50 mW)	100 mA (600 mW)
Energy for 1 measurement	69 µWh	1375 µWh
Typical consumption at 12 V	Automatic standby: less than 3.8 mA* (45.6 mW) Maximum peak current: 250 mA (10 ms)	
Maximum current during measurement	62 mA (744 mW)	150 mA (1800 mW)
Average current during measurement	27 mA (324 mW)	75 mA (900 mW)
Average current (1 measurement / 10s)*	8.5 mA (102 mW)	90 mA (1080 mW)
Energy for 1 measurement	180 µWh	1250 µWh
Typical consumption at 24 V	Automatic standby: less than 4 mA* (96 mW) Maximum peak current: 150 mA (10 ms)	
Maximum current during measurement	60 mA (1440 mW)	100 mA (2400 mW)
Average current during measurement	26 mA (624 mW)	65 mA (1560 mW)
Average current (1 measurement / 10s)*	8.5 mA (204 mW)	45 mA (1080 mW)
Energy for 1 measurement	347 µWh	2167 µWh
EMC compliance	NF EN 61326-1: 2021-06 1,2 RS-485 Modbus RTU 1. The sensor is qualified for standard use with a dedicated cable including power supply and communication lines specific to the sensor network. 2. When connected to a DC power supply network separated from the RS485 communication lines; additional shielding must be used on the system to protect the sensors from induced surges (above 30 meter cable length).	
Warranty	2 years	

*When low power mode is activated in "User Configuration Modbus Registers" (subject to evolution with software updates)

- Never exceed a voltage of 10VDC (absolute maximum rating) on communication lines RS485, A or B, under penalty of irreversible destruction of the transceiver component RS 485.
- SDI-12 (not available): respect the voltage value described in the associated standard (nominal: 5 VDC)
- Always connect ground + shield first.

ELECTRICAL CONNECTIONS

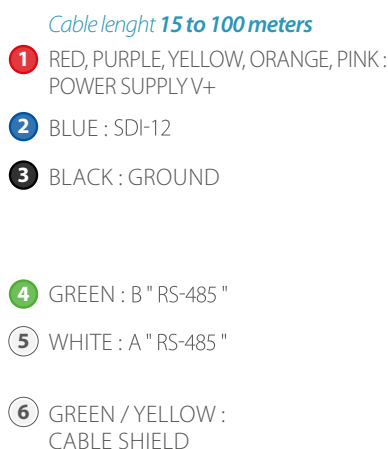
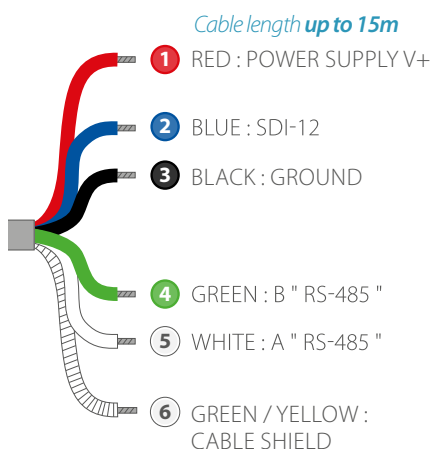

Connect wires 3 and 6 together